

RTA-53



Características do sistema:

RTA-53 é um sistema de batente com rutura térmica, utiliza semi-perfis de alumínio extrudido unidos com barras de poliamida de 24mm, reforçada com fibra de vidro, o que lhe confere elevadas propriedades de isolamento térmico e acústico.

Este sistema contém aros fixos com 53mm e aros móveis com 60,7mm.

Permite a aplicação de bites retos e curvos, com enchimento máximo de 45mm, de abertura interior ou exterior.

O facto deste sistema possuir canal europeu, permite que lhe seja aplicada uma vasta gama de acessórios, conseguindo assim, obter variadas soluções.

Os vedantes, central e batente interior e exterior e de suporte de vidro são em EPDM, conferindo-lhe ótimas prestações herméticas, térmicas e acústicas.

O sistema RTA-53 cumpre as normas da marcação CE (NP-EN 14351-1:2006). Para tal, foi sujeito a ensaios iniciais tipo, em laboratório notificado, ENSATEC.

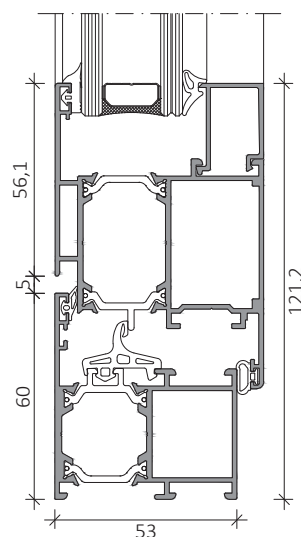
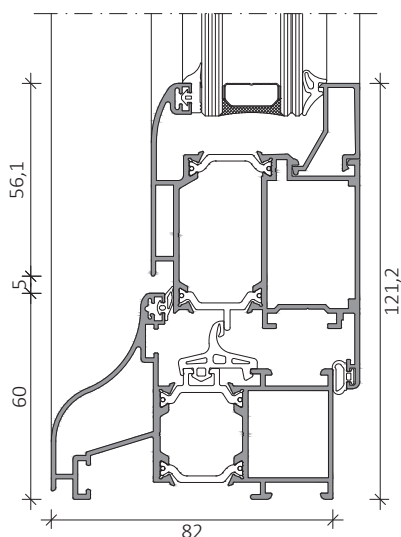
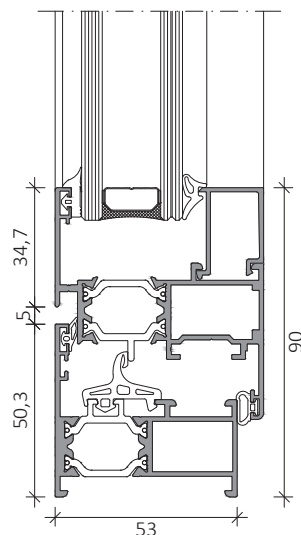
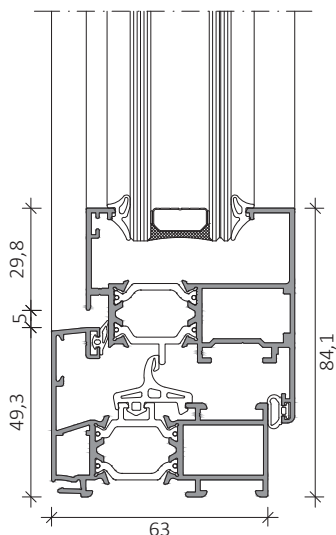

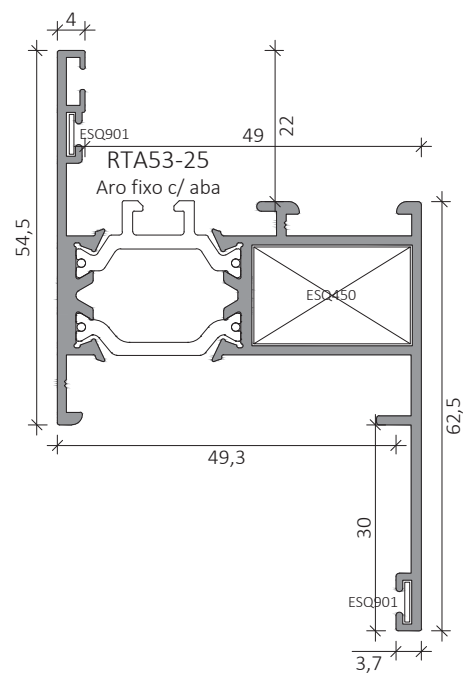
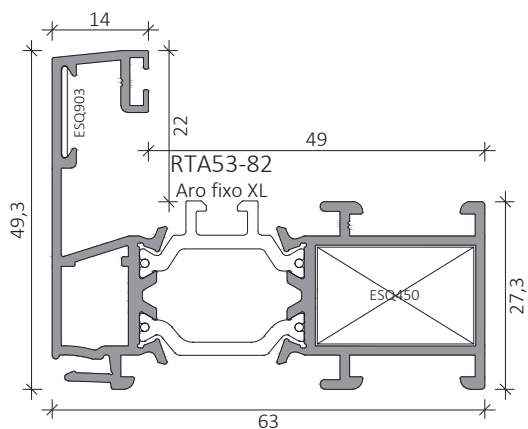
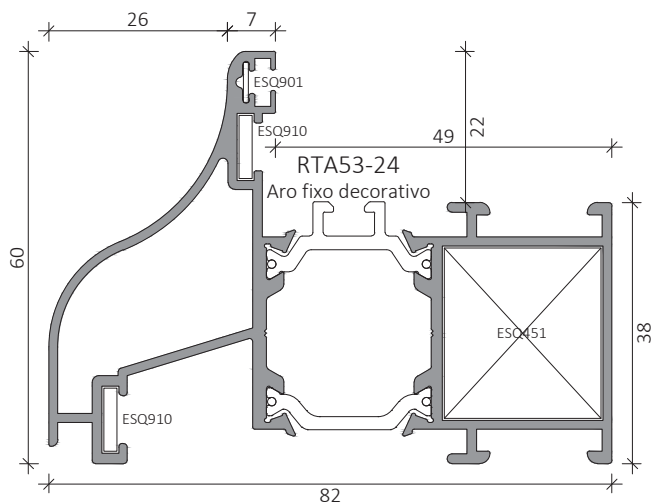
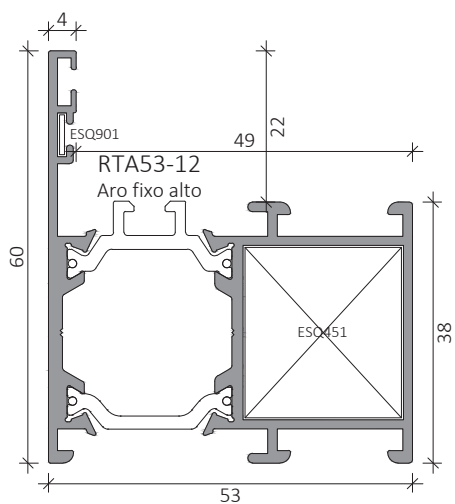
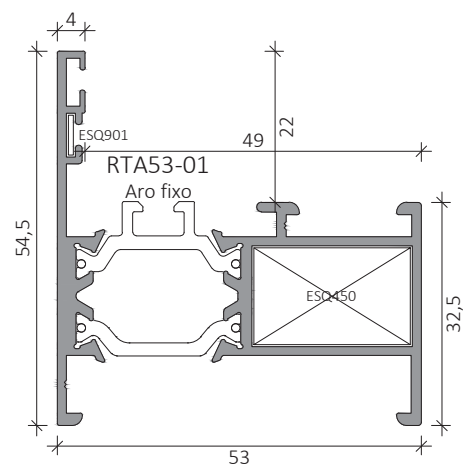
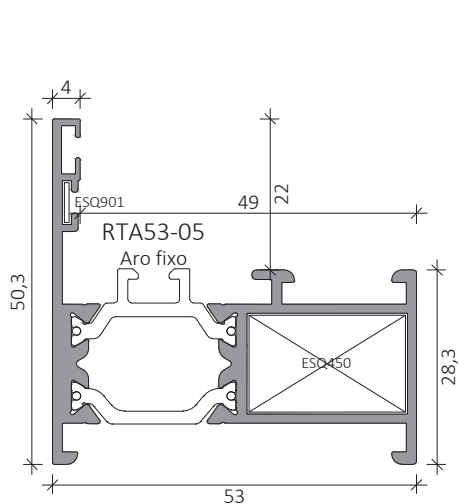

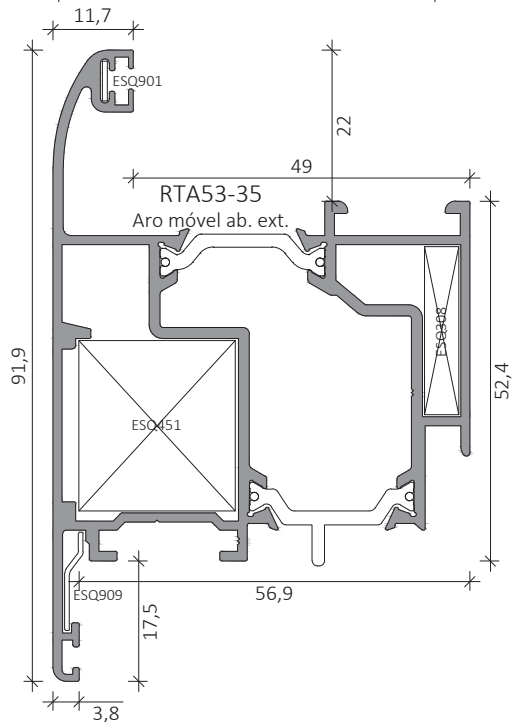
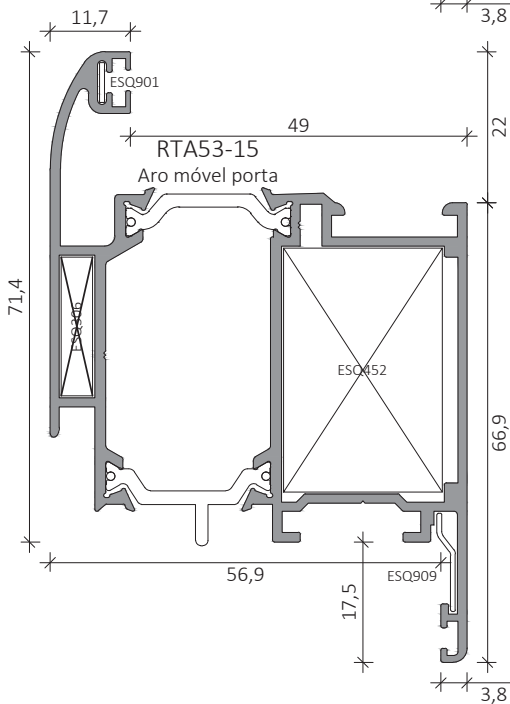
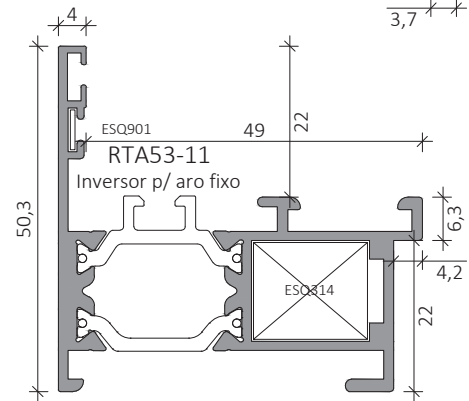
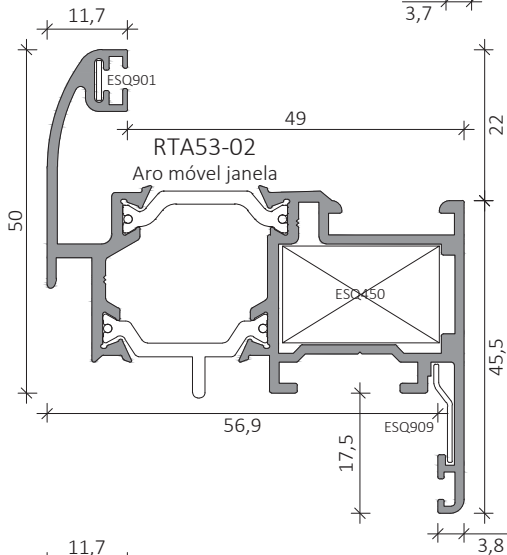
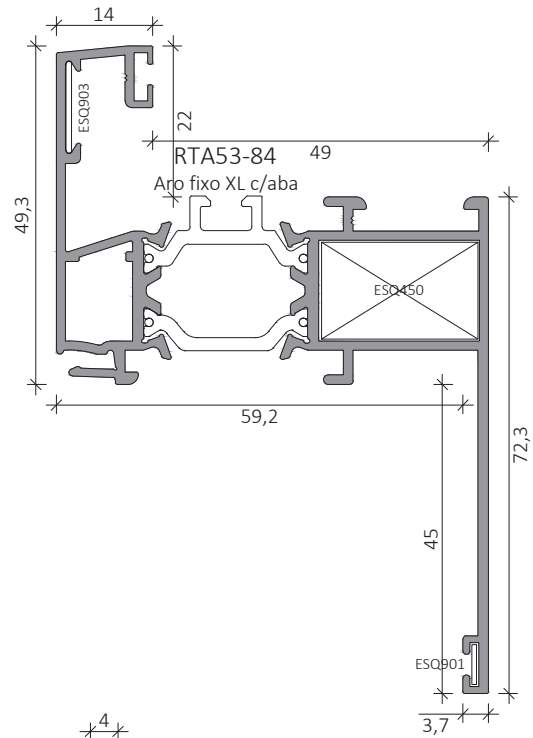
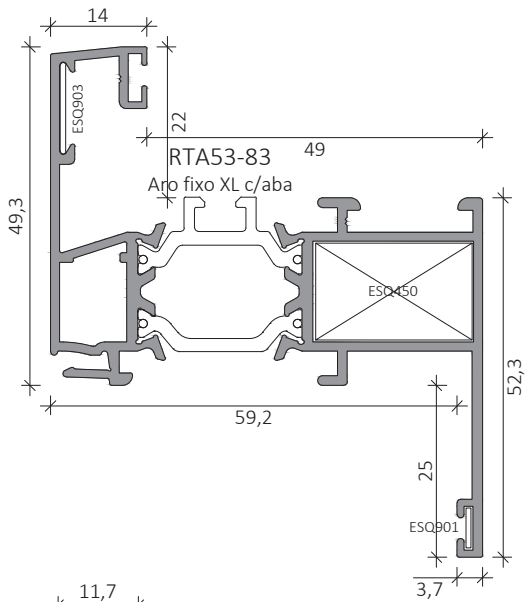

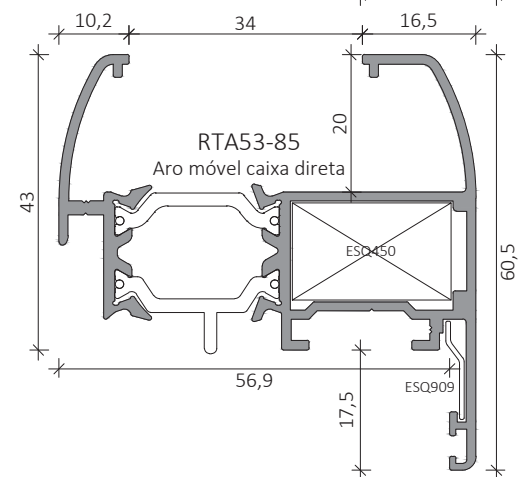
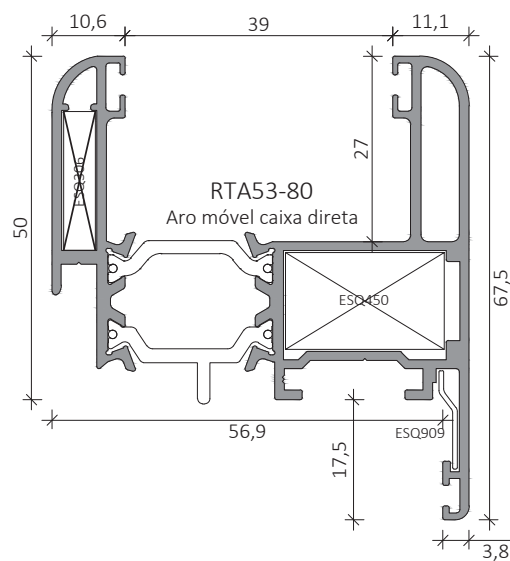
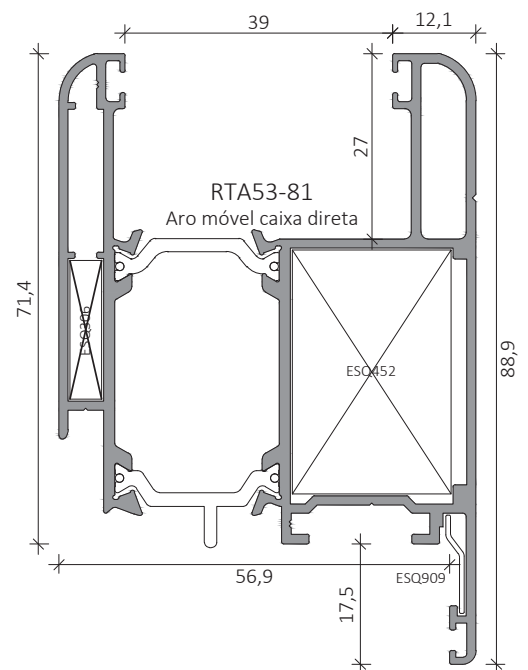
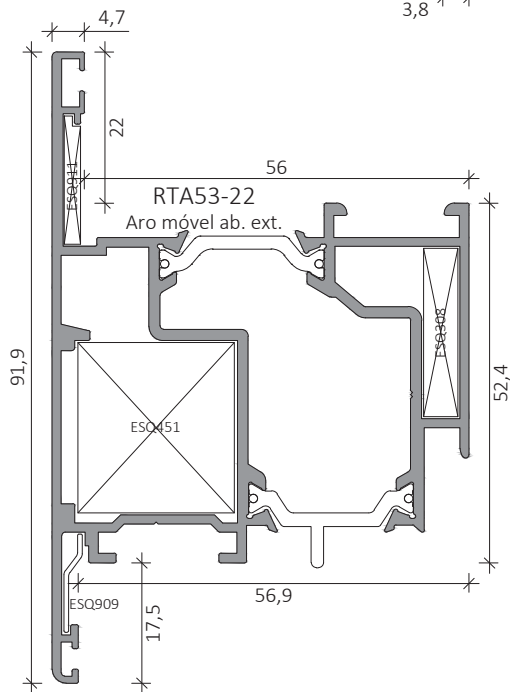
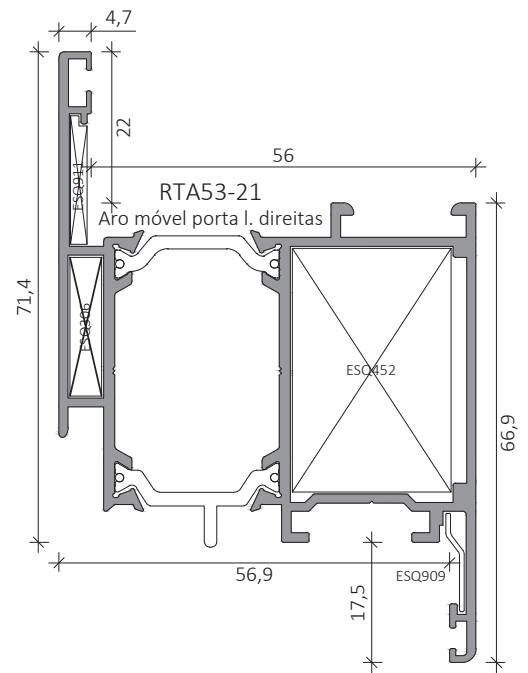
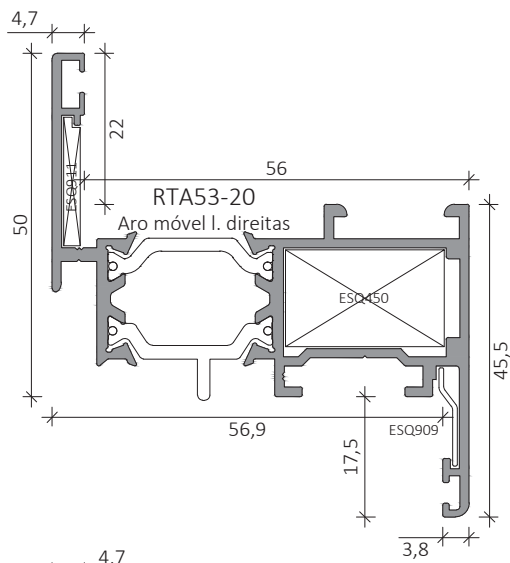

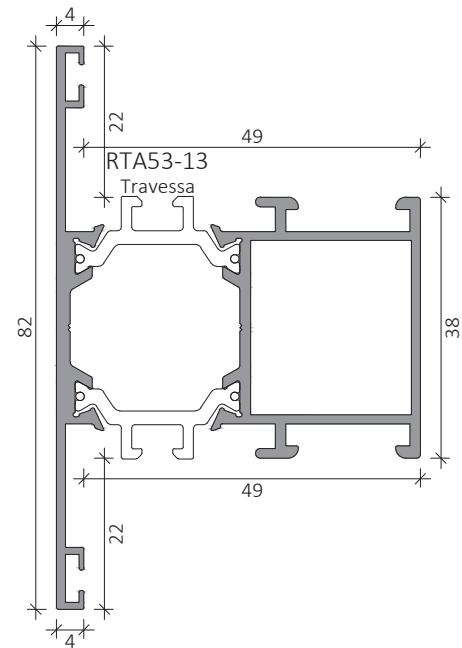
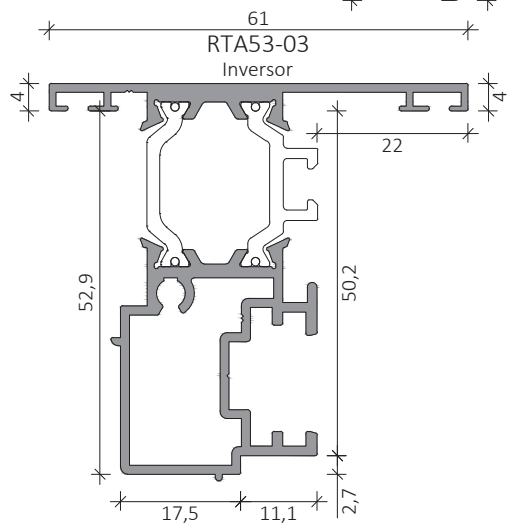
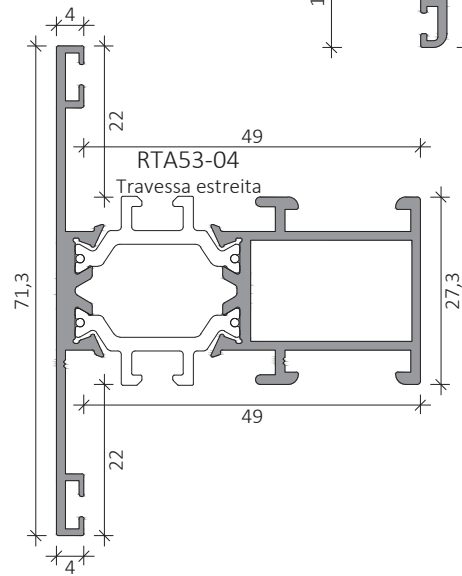
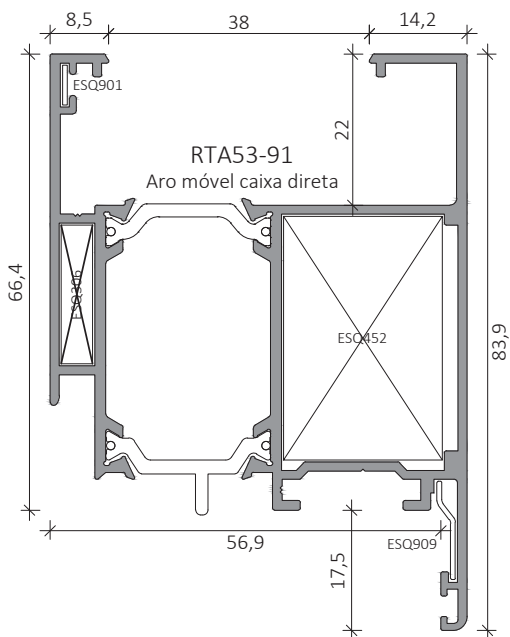
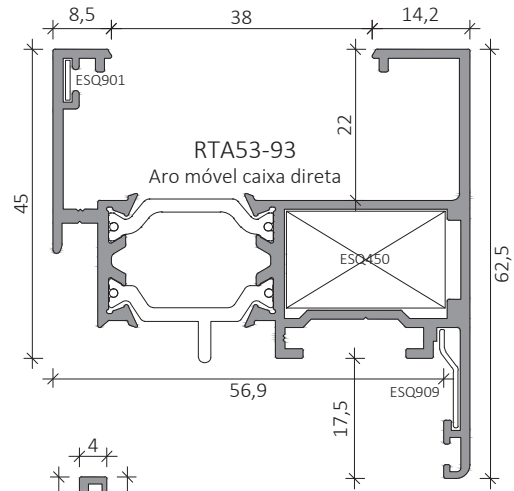
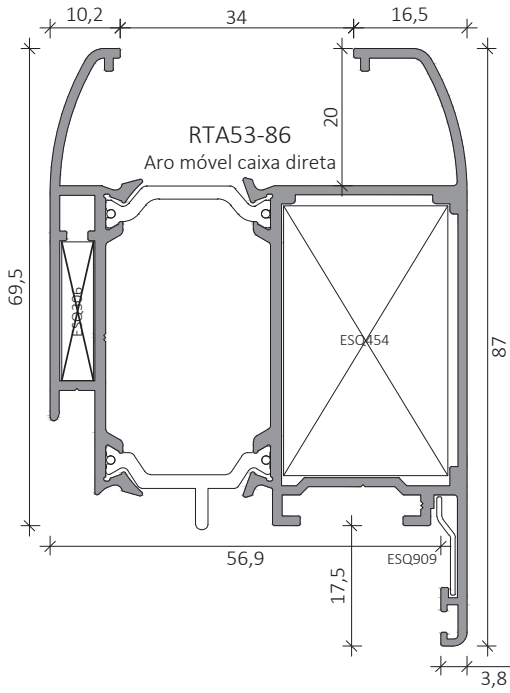

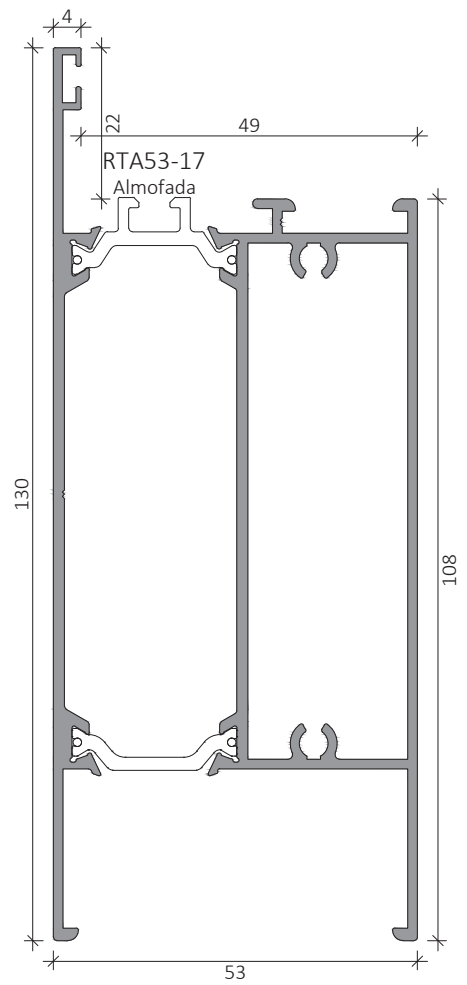
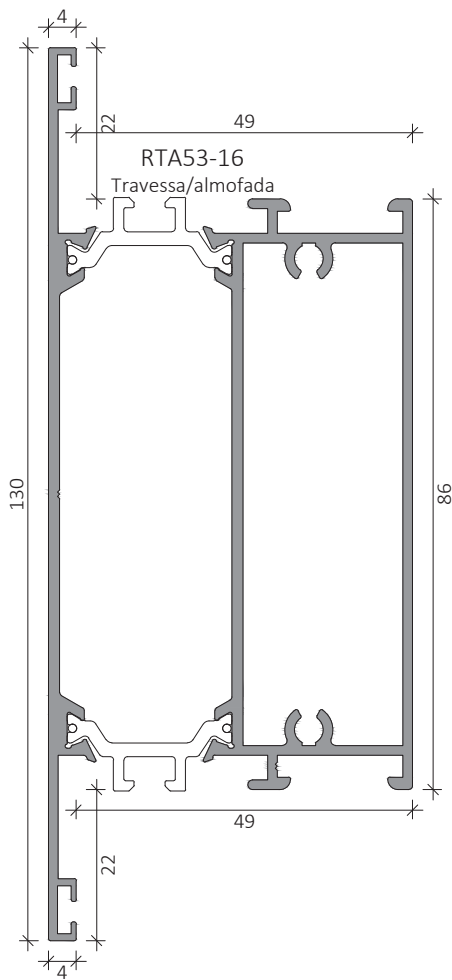
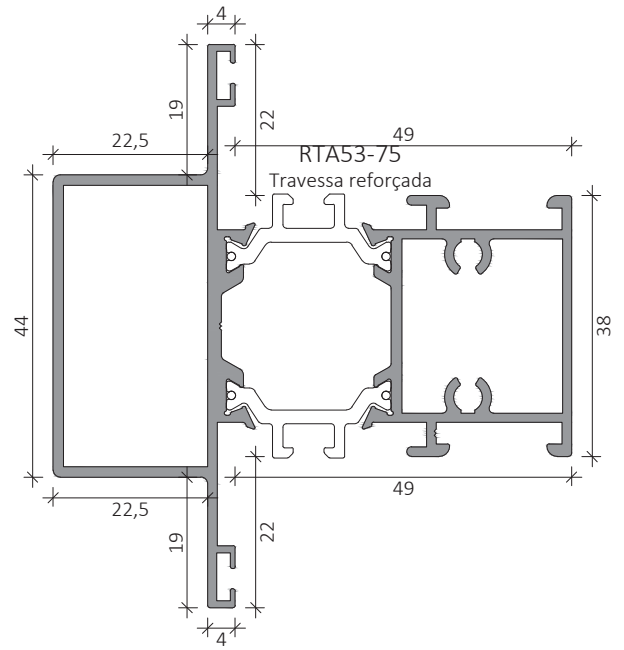
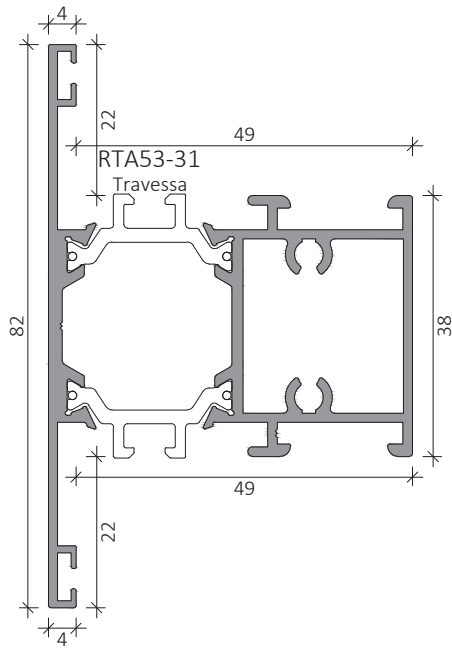

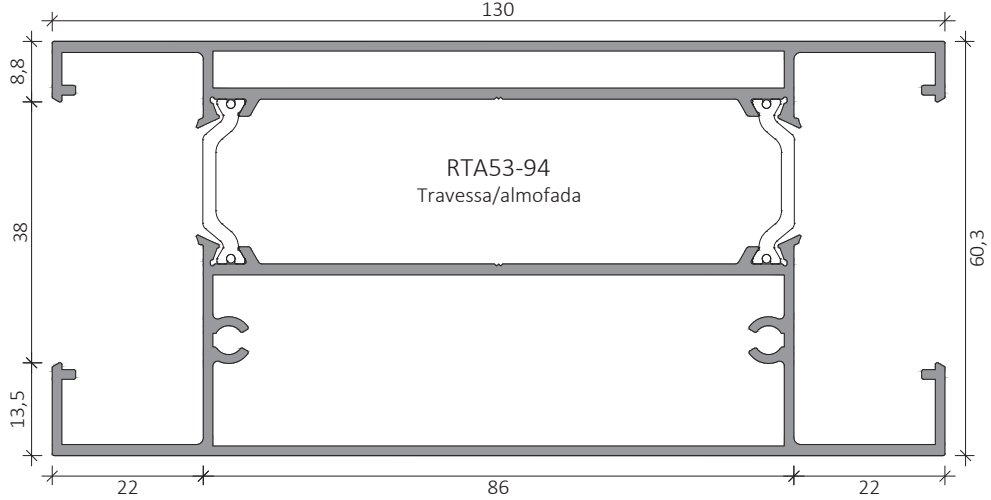
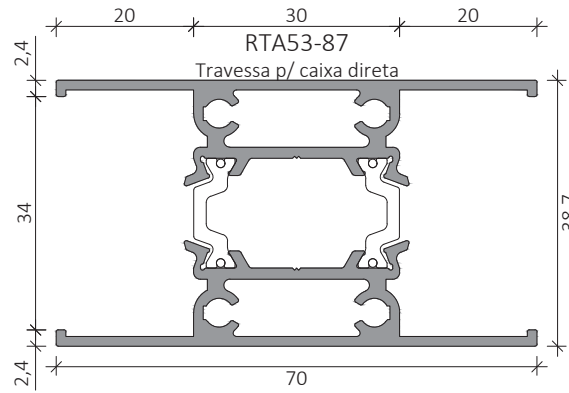
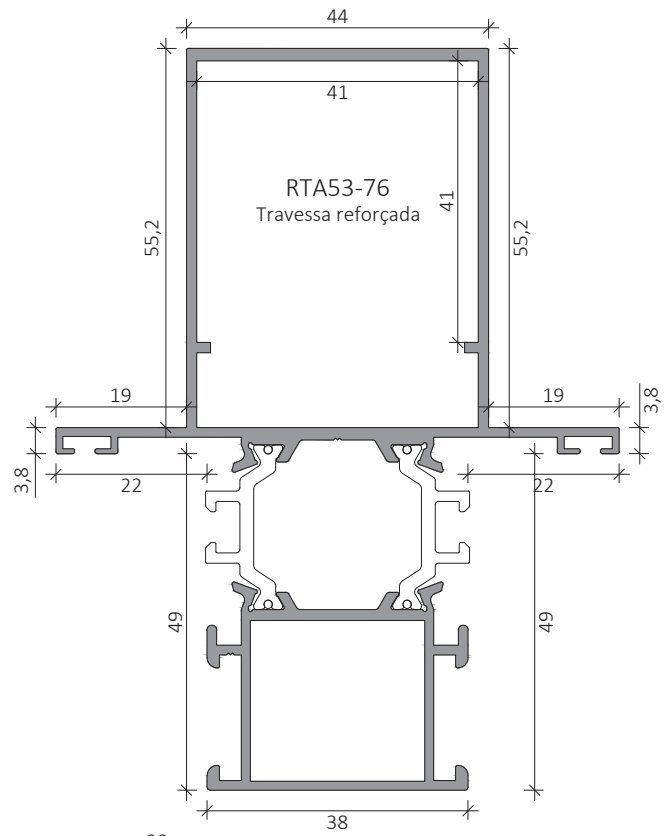
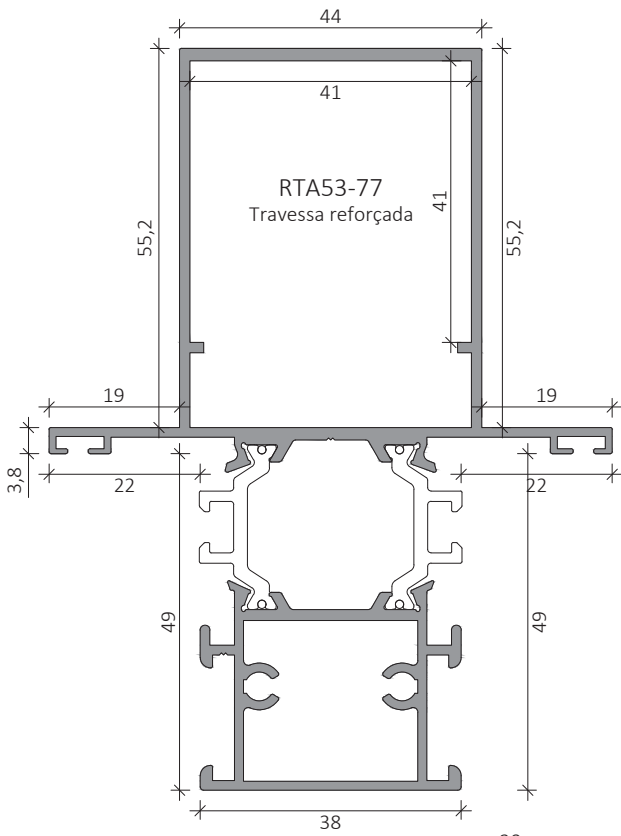

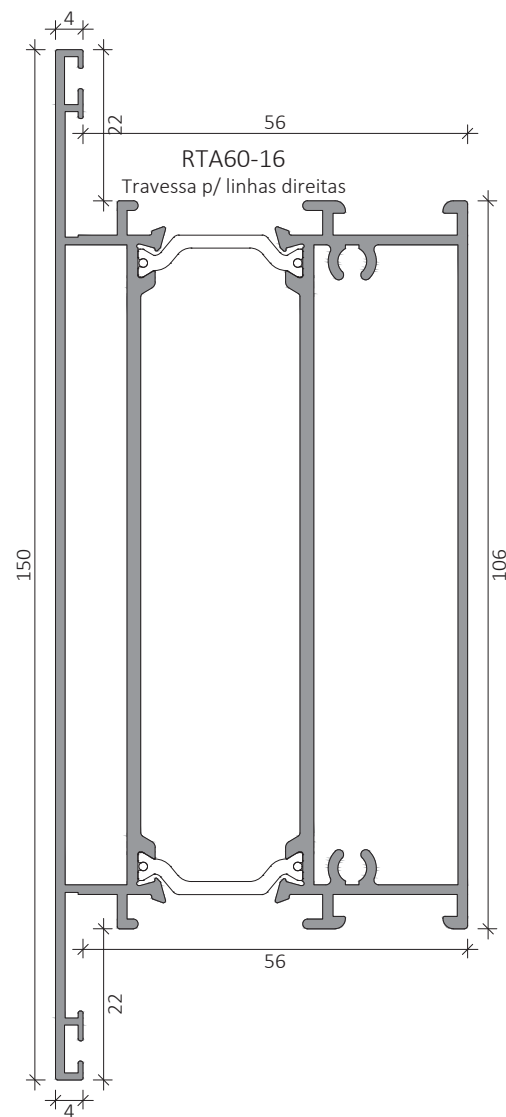
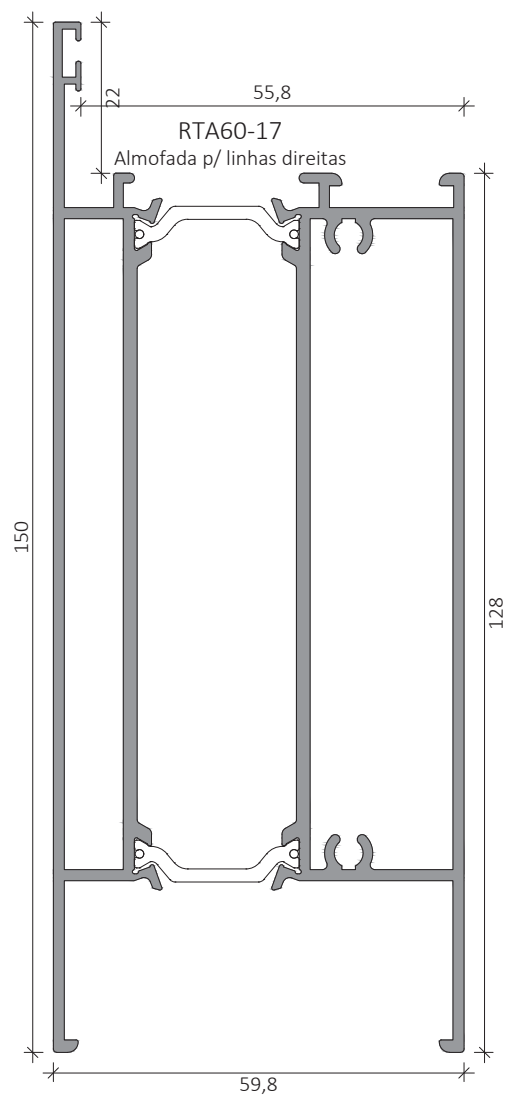
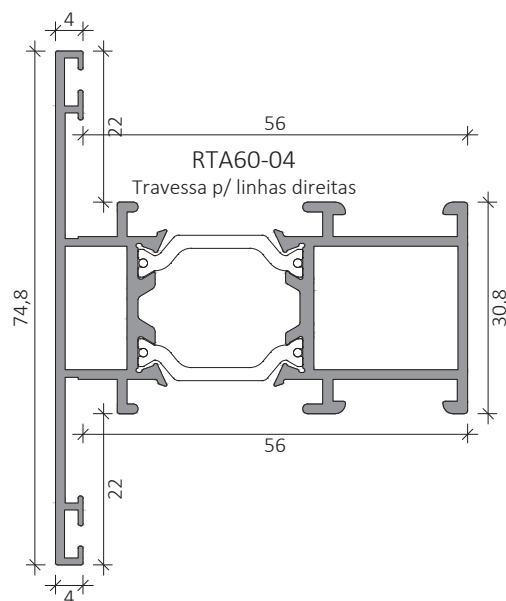
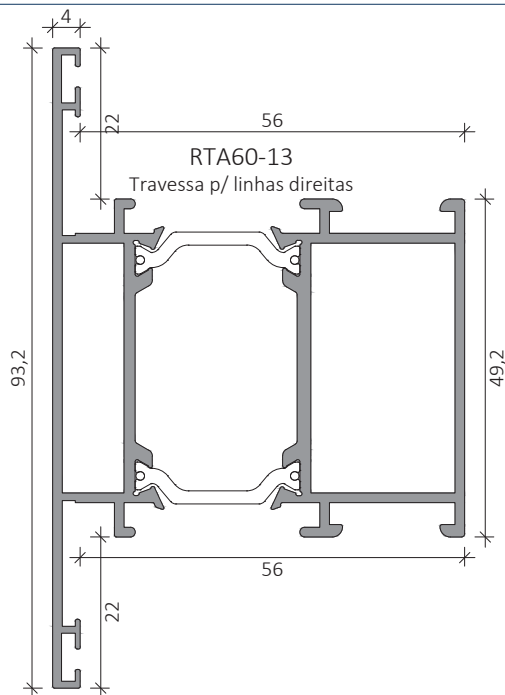

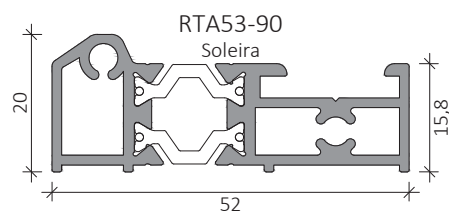
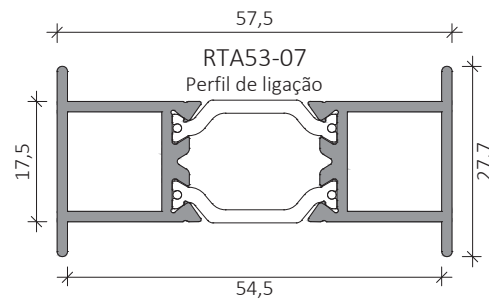
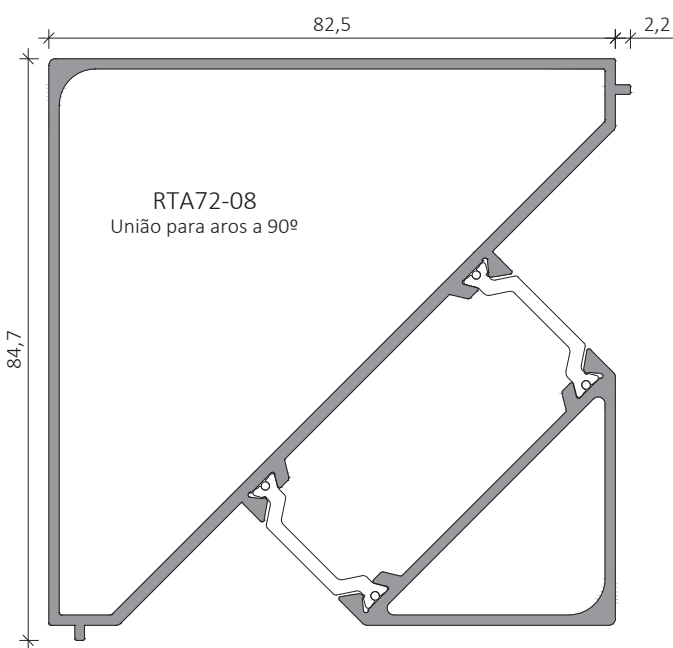
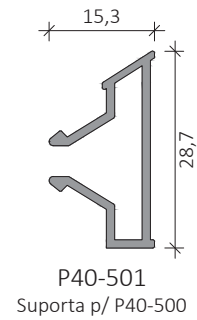
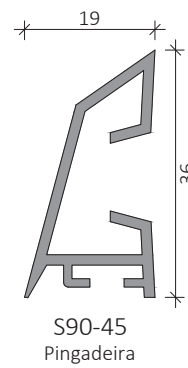
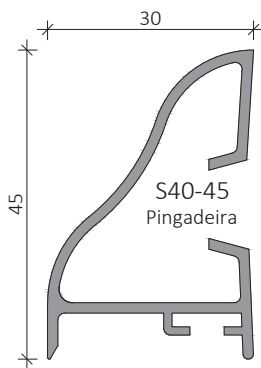
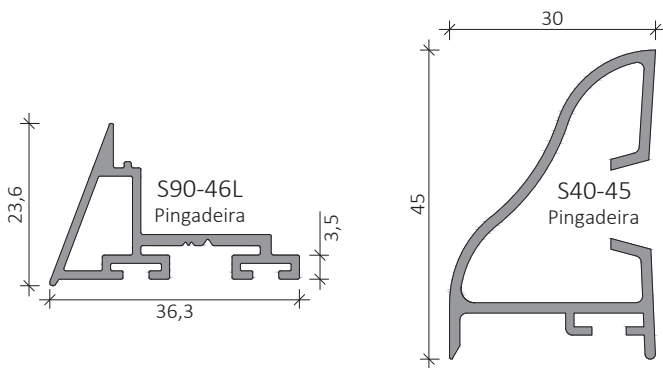
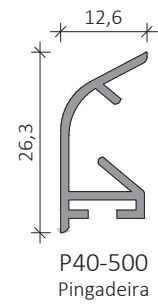
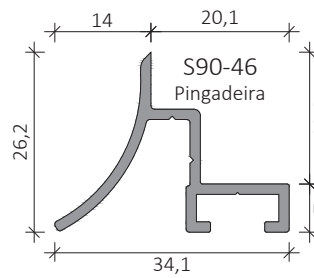
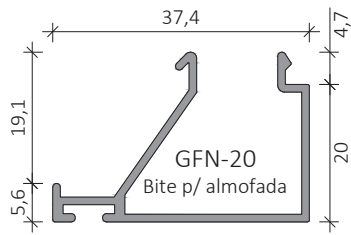
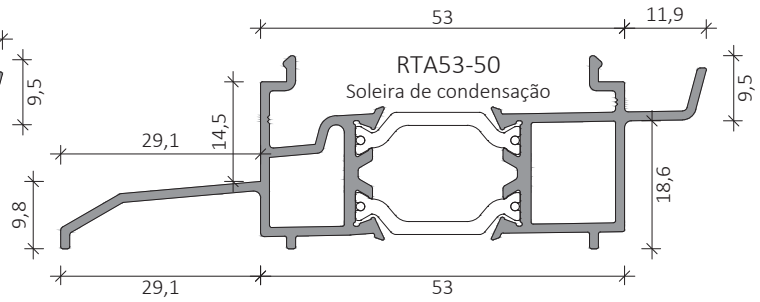
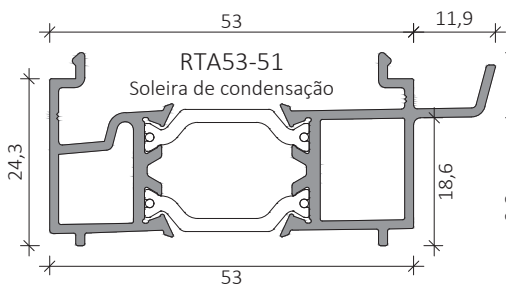

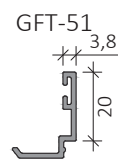
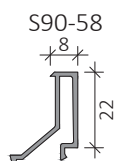
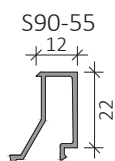
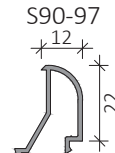
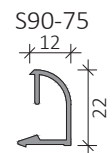
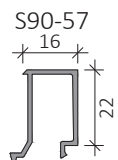
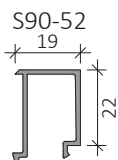
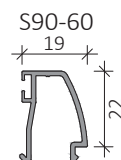
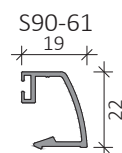
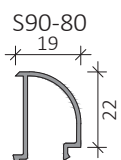
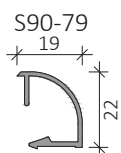
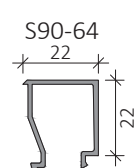
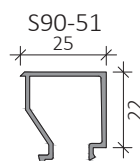
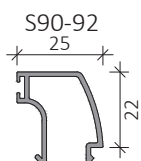
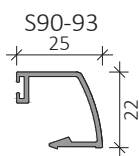
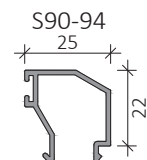
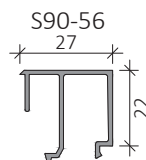
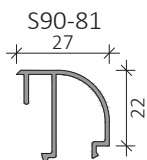
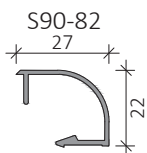
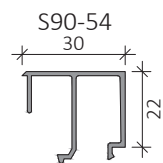
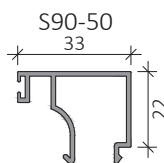
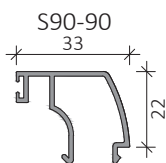
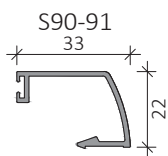

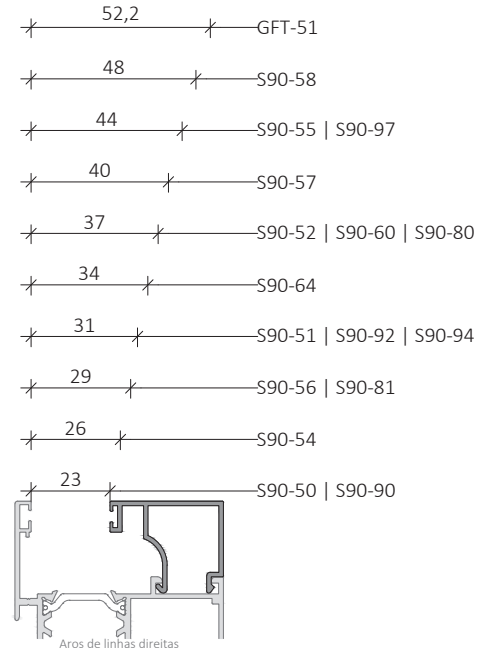
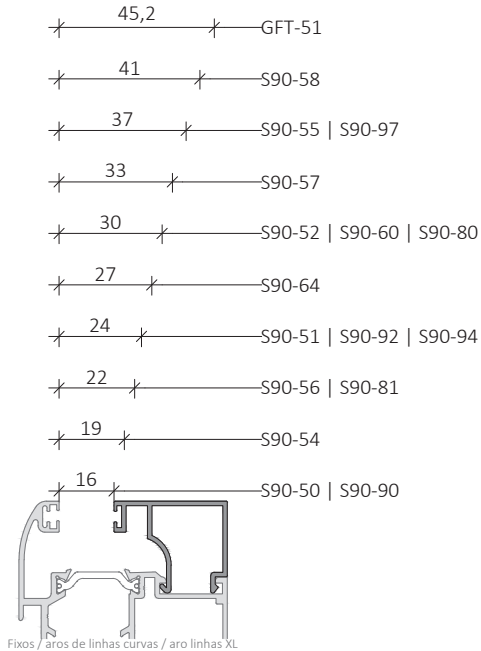

Disposição dos calços

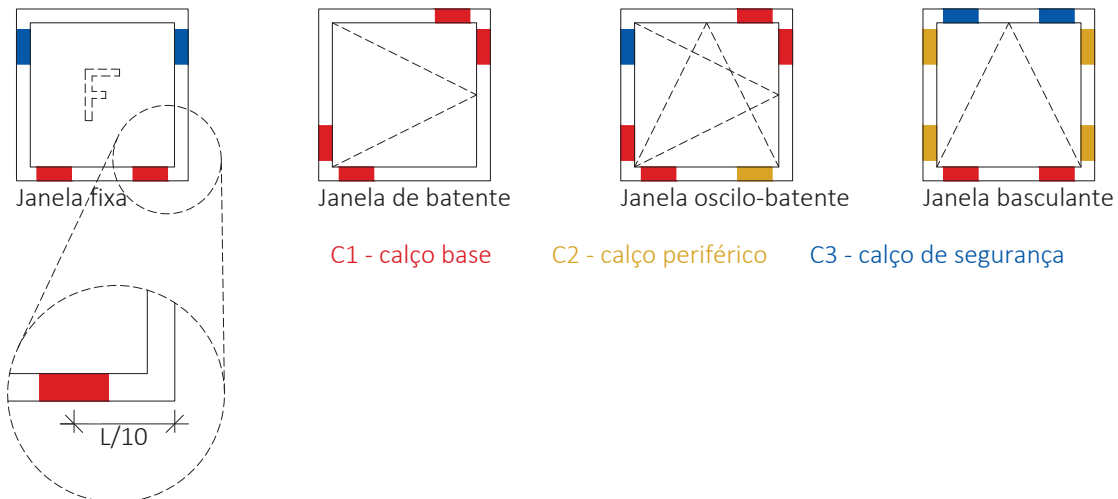

A disposição dos calços em função da sua missão é a indicada nos diferentes tipos de caixilharias aqui representadas. O vidro deve assentar na totalidade sobre os calços base e periféricos.

